

TOP VIEW Standard perforated pattern - 1,024 holes 13/32" dia.

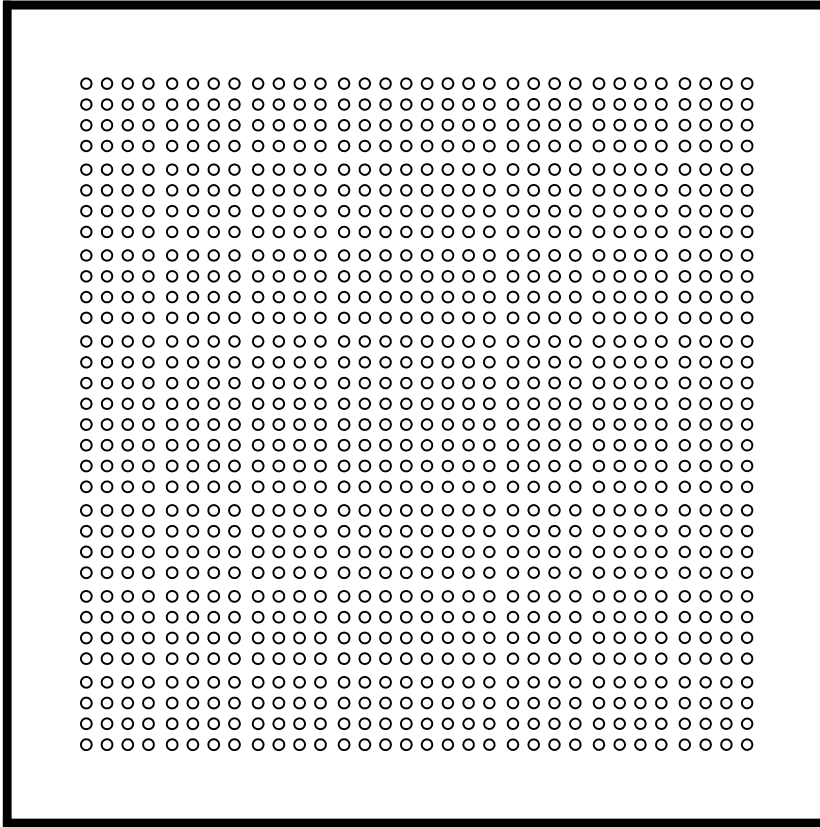

SPECIFICATIONS

General information

- 60 cm square. Panel Weight: 4.75 lbs./ft² (227 Pa) bare.
- Panel height shall be 1.89" (4.8 cm) without covering.
- Die cast aluminum construction.
- 23% open area.
- Class A flame spread rating.
- Non-combustible material.
- Available with coatings.
- Optional standard perforated patterns (refer to FF1250 specification)
- Compatible with FF3000 solids, perforated panels (Refer to FF1250 specification).

UNDERSTRUCTURE OPTIONS

- | | | |
|--|-------------------------------------|---------------------------------|
| <i>System Type</i> | <i>Aluminum Base</i> | <i>Steel Base</i> |
| <i>(Select One)</i> | <i>(Select base)</i> | |
| <input type="checkbox"/> Stringerless | <input type="checkbox"/> Type A 5X5 | <input type="checkbox"/> Type 6 |
| <input type="checkbox"/> Cornerlock | <input type="checkbox"/> Type B 6X6 | |
| <input type="checkbox"/> 2' bolted aluminum stringer | <input type="checkbox"/> Type 800 | |
| | <input type="checkbox"/> Type 600 | |

PACKAGING OPTIONS - refer to FF1250 specification

- Understructure*
- Standard Packaging Cleanroom Packaging
- Panels*
- Standard Packaging Cleanroom Packaging

COVERING OPTIONS

- Tile factory laminated with trim edge or monolithic (mono)
- 1/8" HPL _____ (Color) _____ E-coated
- 1/16" HPL _____ (Color) _____ E-coated
- 1/8" Conductive vinyl _____ (Color) _____ E-coated Mono
- 1/8" Static Dissipative _____ (Color) _____ E-coated Mono
- 1/8" Low Emission Conductive Vinyl _____ (Color) _____ E-coated Mono
- 1/8" Low Emission Static Dissipative _____ (Color) _____ E-coated Mono

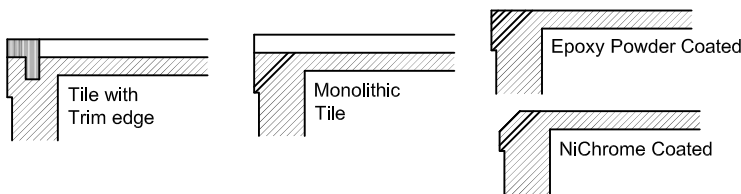

COATING OPTIONS

- Ni Chrome Other _____
- Epoxy Powder Coat (conductive)/(Color) _____
- Epoxy Powder Coat (non-conductive)/(Color) _____

System Performance Criteria

System performance criteria are the most important to consider because they represent the performance in a typical installation. Panel only criteria such as concentrated load is often used to specify floor systems however, the test is not representative of an actual installation because it is performed with the panel resting on blocks, not actual understructure.

System Performance Criteria (Tested on Actual Understructure)*							
System Type	Understructure	SYSTEM WEIGHT	STATIC LOADS		ROLLING LOADS		IMPACT LOADS
			Design Loads	Safety Factor (min. 2.0)	10 Passes	10,000 Passes	
FF1250 Perforated	Stringerless / Cornerlock	6.0 lbs / ft ² 29 kg / m ²	1250 lbs 567 kg	Pass	1000 lbs. 454 kg	1000 lbs. 454 kg	100 lbs. 45.4 kg
	Bolted Stringer	6.5 lbs / ft ² 32 kg / m ²	1250 lbs 567 kg	Pass	1000 lbs. 454 kg	1000 lbs. 454 kg	100 lbs. 45.4 kg

*System load definitions and test procedure descriptions can be found in the Standard Product Tests and Methodology Guidelocated in the Resources section of Tate's web-site, www.tateaccessfloors.com.

BOTTOM VIEW WITH OPTIONAL AIR EXACT DAMPER

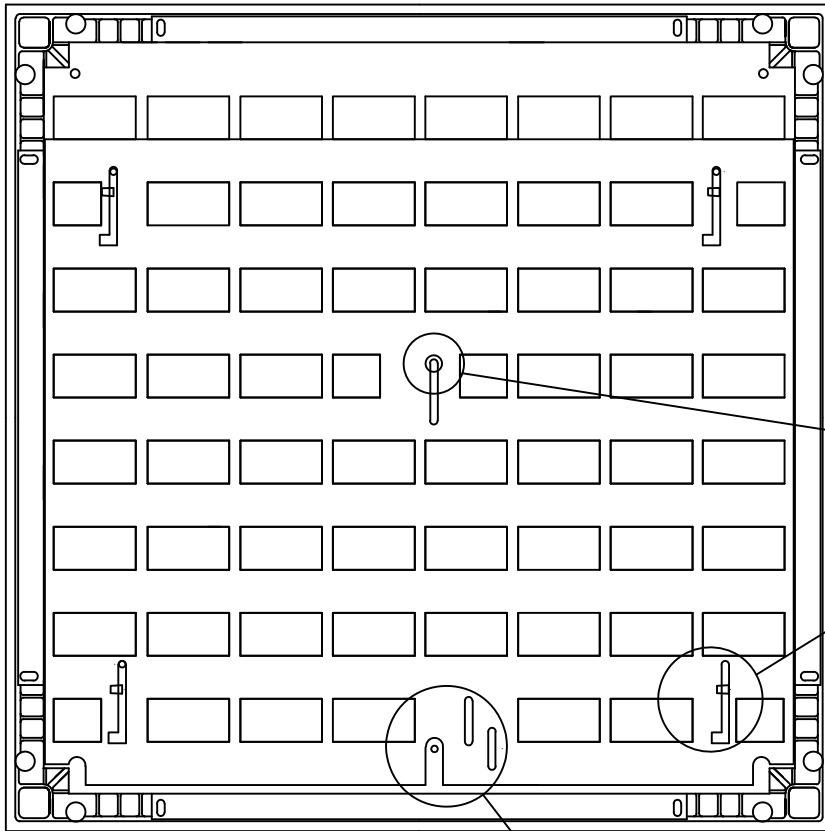

AIR EXACT DAMPER

General information

- Locking feature locks damper at desired setting from top.
- Easily disassembles for cleaning.
- Adjustable from top with standard T-handle allen wrench.
- Compatible with FF1250, FF3000 perforated panels and grates.
- Opening setting is clearly visible from top.
- Same standard 5/32" T-handle allen wrench for adjusting damper and locking it in place.
- Material: Aluminum alloy 5062.
- 55 slotted openings of approximately 0.94 cm X 0.44 cm.

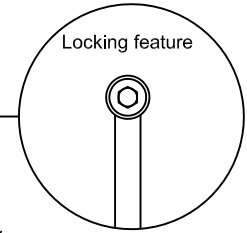

Tab for easy disassembly and cleaning

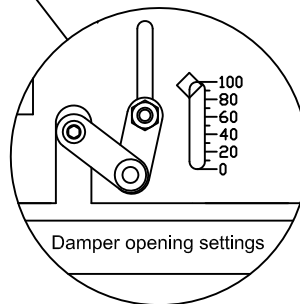

100 represents fully open
0 represents fully closed

DOWNWARD AIR FLOW PERFORMANCE

Standard Holes

Static Pressure (in H ₂ O)	FF1250 Perforated No Damper	Damper Percent Open							
		20%	30%	40%	50%	60%	70%	80%	100%
		Airflow in CFM							
.02	521	241	294	342	385	414	431	470	490
.04	737	341	416	484	545	585	610	664	693
.06	903	417	509	592	668	717	747	814	848
.08	1042	482	588	684	771	828	862	939	980
.10	1165	539	657	764	862	925	964	1050	1095

Downward air flow performance is tested with 1/8" tile with standard 1,024 each 13/32" diameter perforation holes.